

# Current Sensor

Product Series: STK-PL

Part number: STK-80PL  
STK-100PL  
STK-120PL

Version: Ver8.4

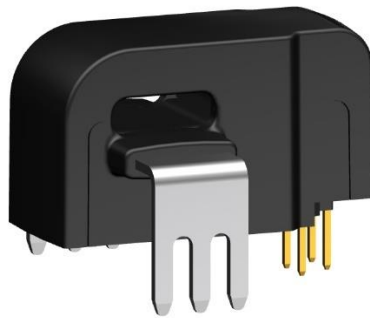

Sinomags Technology Co., Ltd

Web site: [www.sinomags.com](http://www.sinomags.com)

## CONTENT

1.	Summary .....	2
2.	STK-80PL Electrical performance .....	4
3.	STK-100PL Electrical performance.....	5
4.	STK-120PL Electrical performance.....	6
5.	Output voltage VS primary current.....	7
6.	Accuracy characteristics in room temperature .....	8
7.	Accuracy cross temperature.....	9
8.	Frequency response and bandwidth.....	11
9.	Step response time.....	11
10.	Frequency delay performance .....	12
11.	Recommended PCB layout .....	13
12.	Dimension & Pin definitions.....	14
13.	Appendix: typical application circuit .....	15

## 1. Summary

The STK-PL series is based open-loop design. It is suitable for DC, AC, pulsed and any kind of irregular current measurement under the isolated conditions. The nominal current range of the STK-PL current sensor consists of 80A,100A,120A.

### Typical applications

- PV combiner box
- PV inverter (MPPT & AC)
- motor driver controller
- SMPS & UPS
- Battery management system

### Standards

- EN50178:1997
- IEC 61010-1:2010
- IEC 61326-1:2012

### General parameter

Parameter	Symbol	Unit	Value
Working temperature	T_A	°C	-40 ~ 105
Storage temperature	T_stg	°C	-40 ~ 105
Mass	m	g	10

### Absolute maximum rating

Parameter	Symbol	Unit	Value
Supply voltage (non-destructive)	V <sub>C</sub>	V	6.0
ESD rating (HBM)	U <sub>ESD</sub>	kV	4
ESD rating (CDM)	U <sub>CDM</sub>	kV	1.5

Remark: the unrecoverable damage may occur when the product works on the conditions over the absolute maximum ratings. Long-time working on the absolute maximum ratings may cause the degradation on performance and reliability.

**Ratings**

Parameter	Symbol	Unit	Value
Primary involved potential		V AC/DC	600
Ambient operating temperature	T_A	°C	105
Primary current	I_p	A	According to series primary current
Secondary supply voltage	U_c	V DC	5
Output voltage	V_out	V	0.1 ~ 4.9

**Isolation parameter**

Parameter	Symbol	Unit	Value	Comment
RMS voltage for AC test 50Hz/1 min	U <sub>d</sub>	kV	5	
Impulse withstand voltage 1.2/50μs	Ū <sub>w</sub>	kV	8	
Clearance distance (pri. -sec)	d <sub>Cl</sub>	mm	8	Shortest distance through air
Creepage distance (pri. -sec)	d <sub>Cp</sub>	mm	8	Shortest path along device body
Case material			V0 according to UL 94	
Application example		V	600	Reinforced insulation, CAT III, PD 2, non uniform field according EN 50178, IEC 61010
Application example		V	1000	Basic insulation, CAT III, PD 2, non uniform field according EN 50178, IEC 61010
Application example		V	1500	Basic insulation, CAT III, PD 2, according to IEC 62109-1 Altitude ≤ 3000 m
Application example		V	600	CAT III, PD 2, according to UL 508

## 2. STK-80PL Electrical performance

Condition:  $T_A = 25^\circ\text{C}$   $V_{cc} = 5\text{ V}$  (Except special instructions)

Parameter	Symbol	Unit	Min	Typ	Max	Comment
Primary nominal current rms	$I_{pn}$	A		80		
Primary current measuring range	$I_{pm}$	A	-200		200	
Supply voltage	$V_{cc}$	V	4.75	5	5.25	
Current consumption	$I_{cc}$	mA		5	10	
Reference voltage	$V_{ref}$	V	2.48	2.5	2.52	Output function
Rated output voltage	$V_{FS}$	V		0.8		$(V_{out} - V_{ref}) @ I_{pn}$
Internal output resistance	$R_{out}$	$\Omega$		1		Output
Quiescent voltage	$V_{off}$	V	2.48	2.5	2.52	$V_{out} @ 0\text{ A}$
Electrical offset voltage	$V_{oe}$	mV	-10		10	$(V_{out} - V_{ref}) @ 0\text{ A}$
Temperature drift of $V_{oe}$	$V_{oe\_TRange}$	% $V_{FS}$	-1.5		1.5	$-40^\circ\text{C} \sim 105^\circ\text{C}$
Magnetic offset current	$I_{om}$	A	-0.25		0.25	@ $\pm 10 \times I_{pn}$
Theoretical gain	$G_{th}$	mV/A		10		800 mV @ $I_{pn}$
Error of gain	$Err\_G$	% $G_{th}$		$\pm 1$		Trimmed in the factory @ $25^\circ\text{C}$
Temperature drift of gain	$G\_TR$	% $G_{th}$	-1.0		1.0	$-40^\circ\text{C} \sim 105^\circ\text{C}$
Rated linearity error	$Non-L_{pn}$	% $I_{pn}$	-0.5		0.5	$\pm I_{pn}$
Linearity error @ $I_{pm}$	$Non-L_{pm}$	% $I_{pm}$	-3		3	$\pm I_{pm}$
Reaction time	$t_{ra}$	$\mu\text{s}$		0.5		@ 10% of $I_{pn}$
Step response time	$t_{res}$	$\mu\text{s}$		2	2.5	@ 90% of $I_{pn}$
Delay time	$t_{delay}$	$\mu\text{s}$		1		200 kHz sine wave
Frequency bandwidth (-3dB)	BW	kHz		200		No RC circuit
Output voltage noise	$V_{noise}$	mVpp		10		
DC ~ 10 kHz				15		
DC ~ 100 kHz						
Accuracy @ $25^\circ\text{C}$	X	% of $I_{pn}$	-1		1	@ $25^\circ\text{C}$
Accuracy @ $-40^\circ\text{C} \sim 105^\circ\text{C}$	$X\_TRange$	% of $I_{pn}$	-3		3	$-40^\circ\text{C} \sim 105^\circ\text{C}$

### 3. STK-100PL Electrical performance

Condition:  $T_A = 25^\circ\text{C}$   $V_{cc} = 5\text{ V}$  (Except special instructions)

Parameter	Symbol	Unit	Min	Typ	Max	Comment
Primary nominal current rms	$I_{pn}$	A		100		
Primary current measuring range	$I_{pm}$	A	-250		250	
Supply voltage	$V_{cc}$	V	4.75	5	5.25	
Current consumption	$I_{cc}$	mA		5	10	
Reference voltage	$V_{ref}$	V	2.48	2.5	2.52	Output function
Rated output voltage	$V_{FS}$	V		0.8		$(V_{out} - V_{ref}) @ I_{pn}$
Internal output resistance	$R_{out}$	$\Omega$		1		Output
Quiescent voltage	$V_{off}$	V	2.48	2.5	2.52	$V_{out} @ 0\text{ A}$
Electrical offset voltage	$V_{oe}$	mV	-10		10	$(V_{out} - V_{ref}) @ 0\text{ A}$
Temperature drift of $V_{oe}$	$V_{oe\_TRange}$	% $V_{FS}$	-1.5		1.5	$-40^\circ\text{C} \sim 105^\circ\text{C}$
Magnetic offset current	$I_{om}$	A	-0.25		0.25	@ $\pm 10 \times I_{pn}$
Theoretical gain	$G_{th}$	mV/A		8		800 mV @ $I_{pn}$
Error of gain	$Err\_G$	% $G_{th}$		$\pm 1$		Trimmed in the factory @ $25^\circ\text{C}$
Temperature drift of gain	$G\_TR$	% $G_{th}$	-1.0		1.0	$-40^\circ\text{C} \sim 105^\circ\text{C}$
Rated linearity error	$Non-L_{pn}$	% $I_{pn}$	-0.5		0.5	$\pm I_{pn}$
Linearity error @ $I_{pm}$	$Non-L_{pm}$	% $I_{pm}$	-3		3	$\pm I_{pm}$
Reaction time	$t_{ra}$	$\mu\text{s}$		0.5		@ 10% of $I_{pn}$
Step response time	$t_{res}$	$\mu\text{s}$		2	2.5	@ 90% of $I_{pn}$
Delay time	$t_{delay}$	$\mu\text{s}$		1		200 kHz sine wave
Frequency bandwidth (-3dB)	BW	kHz		200		No RC circuit
Output voltage noise	$V_{noise}$	mVpp		10		
DC ~ 10 kHz				15		
DC ~ 100 kHz						
Accuracy @ $25^\circ\text{C}$	X	% of $I_{pn}$	-1		1	@ $25^\circ\text{C}$
Accuracy @ $-40^\circ\text{C} \sim 105^\circ\text{C}$	$X\_TRange$	% of $I_{pn}$	-3		3	$-40^\circ\text{C} \sim 105^\circ\text{C}$

## 4. STK-120PL Electrical performance

Condition:  $T_A = 25^\circ\text{C}$   $V_{cc} = 5\text{ V}$  (Except special instructions)

Parameter	Symbol	Unit	Min	Typ	Max	Comment
Primary nominal current rms	$I_{pn}$	A		120		
Primary current measuring range	$I_{pm}$	A	-300		300	
Supply voltage	$V_{cc}$	V	4.75	5	5.25	
Current consumption	$I_{cc}$	mA		5	10	
Reference voltage	$V_{ref}$	V	2.48	2.5	2.52	Output function
Rated output voltage	$V_{FS}$	V		0.8		$(V_{out} - V_{ref}) @ I_{pn}$
Internal output resistance	$R_{out}$	$\Omega$		1		Output
Quiescent voltage	$V_{off}$	V	2.48	2.5	2.52	$V_{out} @ 0\text{ A}$
Electrical offset voltage	$V_{oe}$	mV	-10		10	$(V_{out} - V_{ref}) @ 0\text{ A}$
Temperature drift of $V_{oe}$	$V_{oe\_TRange}$	% $V_{FS}$	-1.5		1.5	$-40^\circ\text{C} \sim 105^\circ\text{C}$
Magnetic offset current	$I_{om}$	A	-0.25		0.25	@ $\pm 10 \times I_{pn}$
Theoretical gain	$G_{th}$	mV/A		6.667		800 mV @ $I_{pn}$
Error of gain	$Err_G$	% $G_{th}$		$\pm 1$		Trimmed in the factory @ $25^\circ\text{C}$
Temperature drift of gain	$G_{TR}$	% $G_{th}$	-1.0		1.0	$-40^\circ\text{C} \sim 105^\circ\text{C}$
Rated linearity error	Non- $I_{pn}$	% $I_{pn}$	-0.5		0.5	$\pm I_{pn}$
Linearity error @ $I_{pm}$	Non- $I_{pm}$	% $I_{pm}$	-3		3	$\pm I_{pm}$
Reaction time	$t_{ra}$	$\mu\text{s}$		0.5		@ 10% of $I_{pn}$
Step response time	$t_{res}$	$\mu\text{s}$		2	2.5	@ 90% of $I_{pn}$
Delay time	$t_{delay}$	$\mu\text{s}$		1		200 kHz sine wave
Frequency bandwidth (-3dB)	BW	kHz		200		No RC circuit
Output voltage noise	$V_{noise}$	mVpp		10		
DC ~ 10 kHz				15		
DC ~ 100 kHz						
Accuracy @ $25^\circ\text{C}$	X	% of $I_{pn}$	-1		1	@ $25^\circ\text{C}$
Accuracy @ $-40^\circ\text{C} \sim 105^\circ\text{C}$	$X_{TRange}$	% of $I_{pn}$	-3		3	$-40^\circ\text{C} \sim 105^\circ\text{C}$

### 5. Output voltage VS primary current

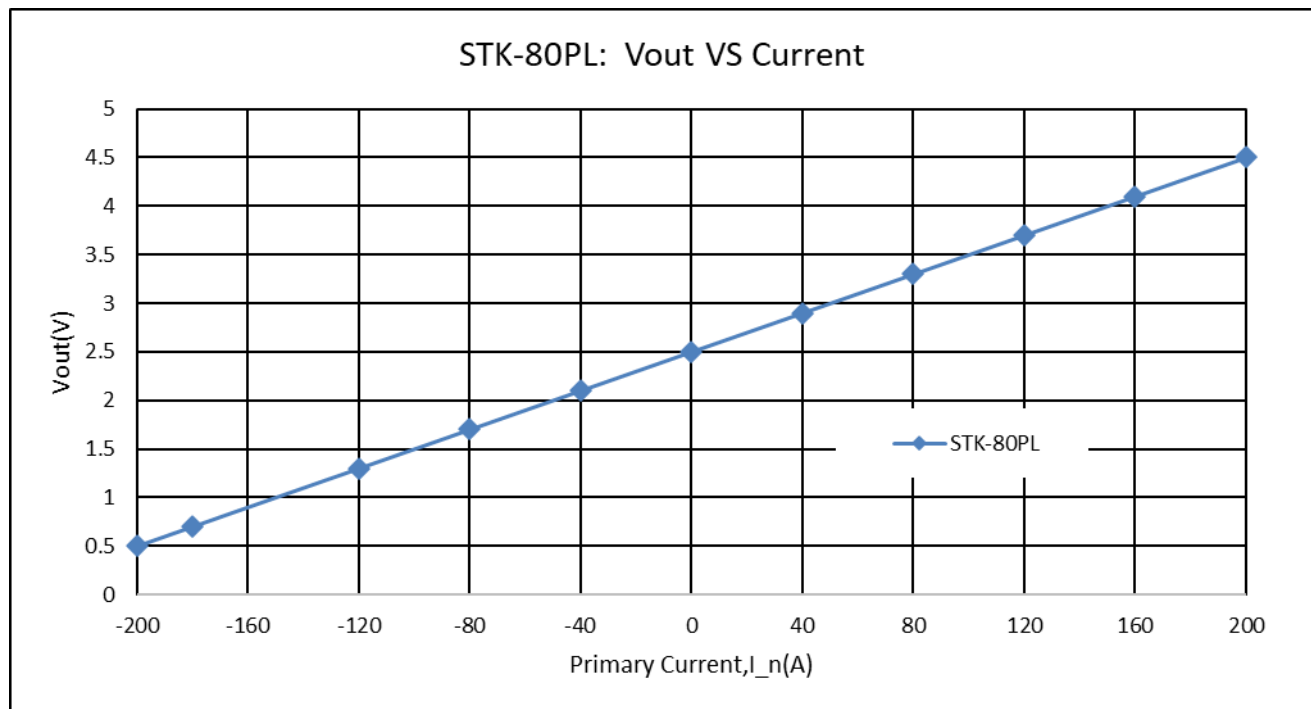

The dependence of Vout of STK-80PL on the primary current.

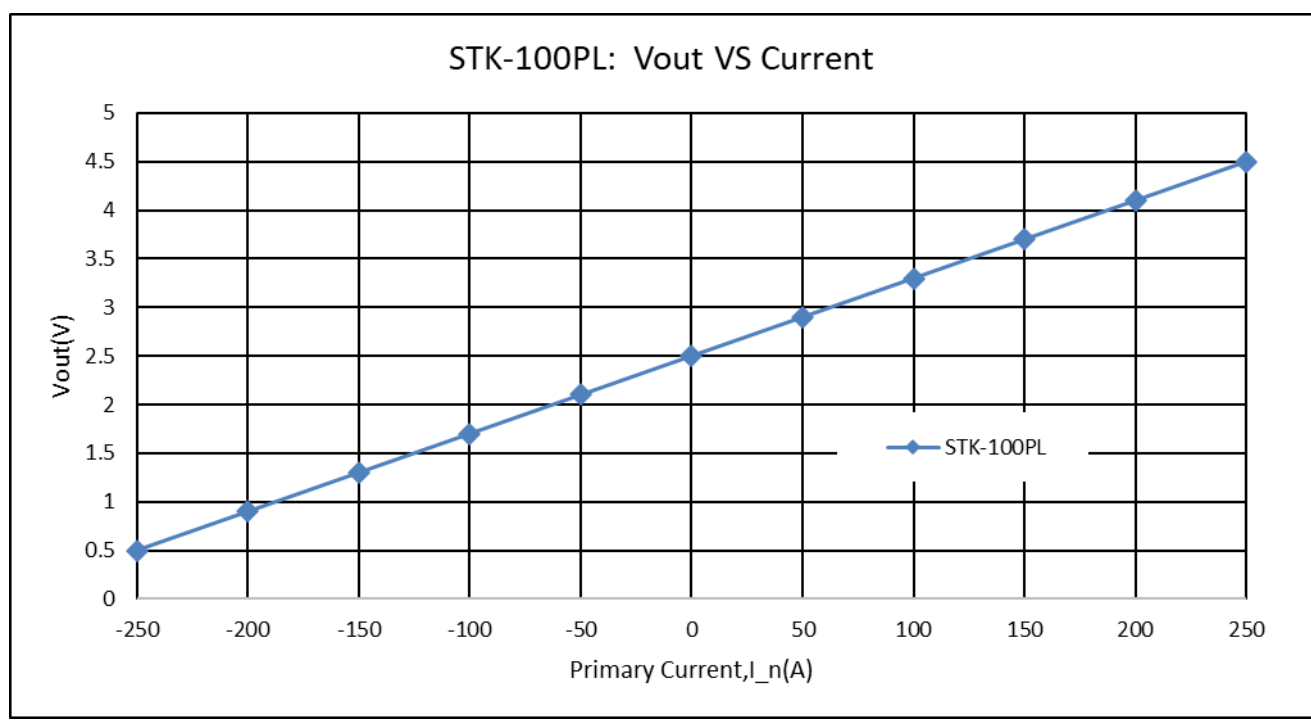

The dependence of Vout of STK-100PL on the primary current.



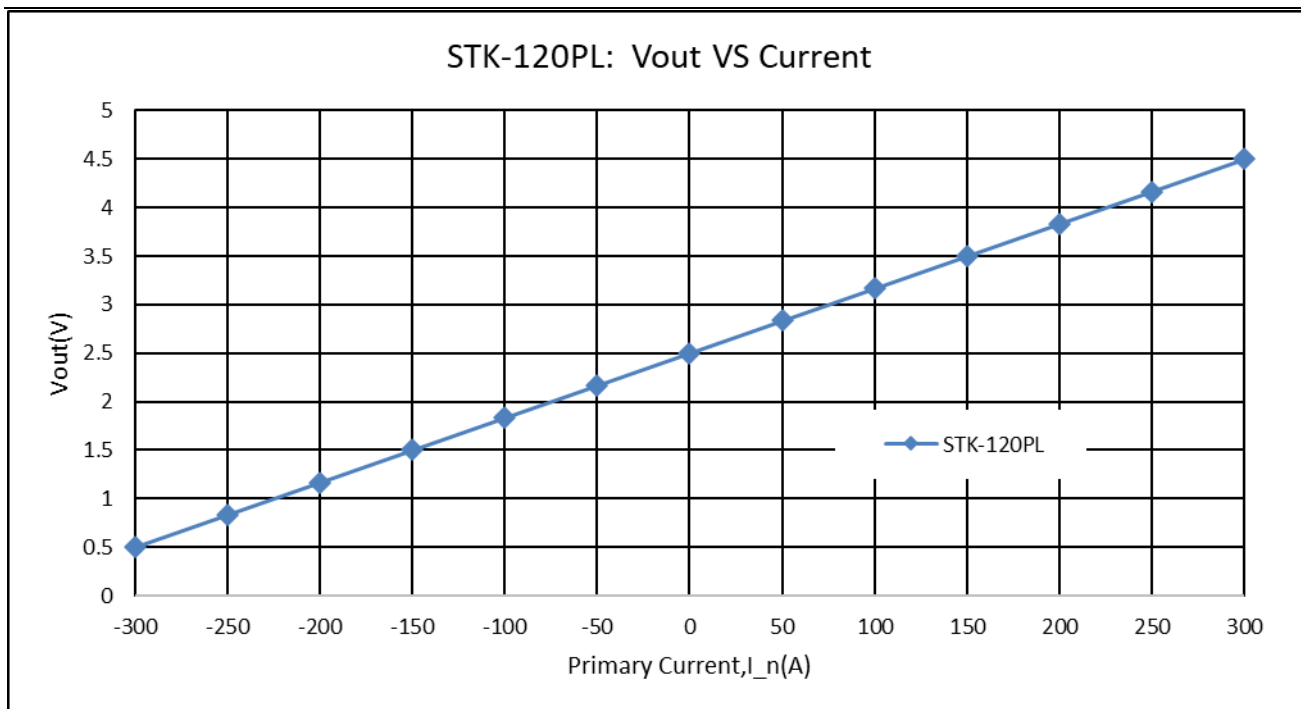

The dependence of Vout of STK-120PL on the primary current.

## 6. Accuracy characteristics in room temperature

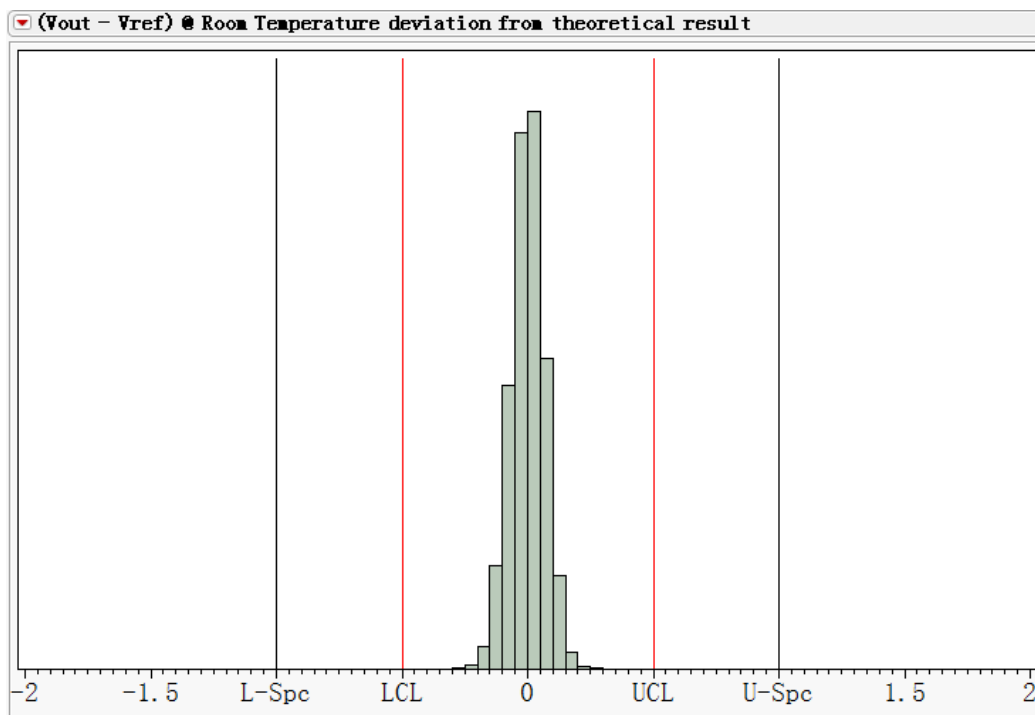

The error of STK-PL current sensor at 25°C compared with the standard output,  $((V_{out} - V_{ref})_{measure} @ I_n @ 25^{\circ}C - V_{oe}@25^{\circ}C - G_{th} * I_n) / V_{FS}$ . Vout represents voltage of Vout, Vref the voltage of Vref, I<sub>n</sub> the primary current, V<sub>oe</sub> the (Vout - Vref)@0A, G<sub>th</sub> the theoretical gain, V<sub>FS</sub> the rated output voltage.

## 7. Accuracy cross temperature

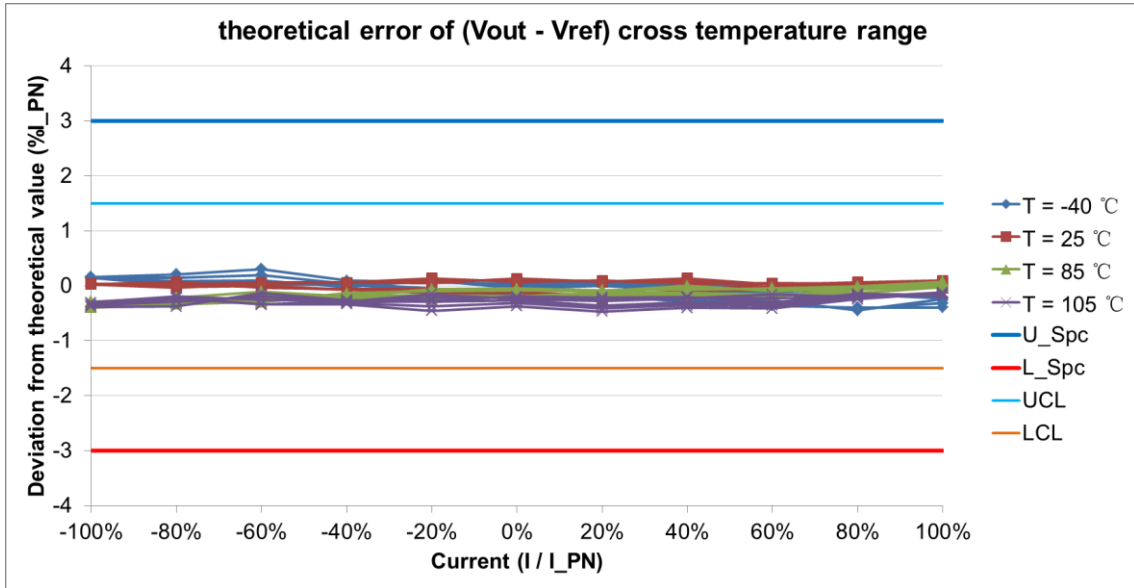

The error of STK-PL current sensor at  $-40^{\circ}\text{C} \sim 105^{\circ}\text{C}$  compared with the standard output at room temperature,  $((V_{out} - V_{ref})_{measure} @ I_n @ T_x - V_{oe} @ T_x - G_{th} * I_n) / V_{FS}$ . Where,  $V_{out}$  represents voltage of  $V_{out}$ ,  $V_{ref}$  the voltage of  $V_{ref}$ ,  $I_n$  the primary current,  $T_x$  the present temperature,  $V_{oe}$  the  $(V_{out} - V_{ref}) @ 0A$ ,  $G_{th}$  the theoretical gain,  $V_{FS}$  the rated output voltage.

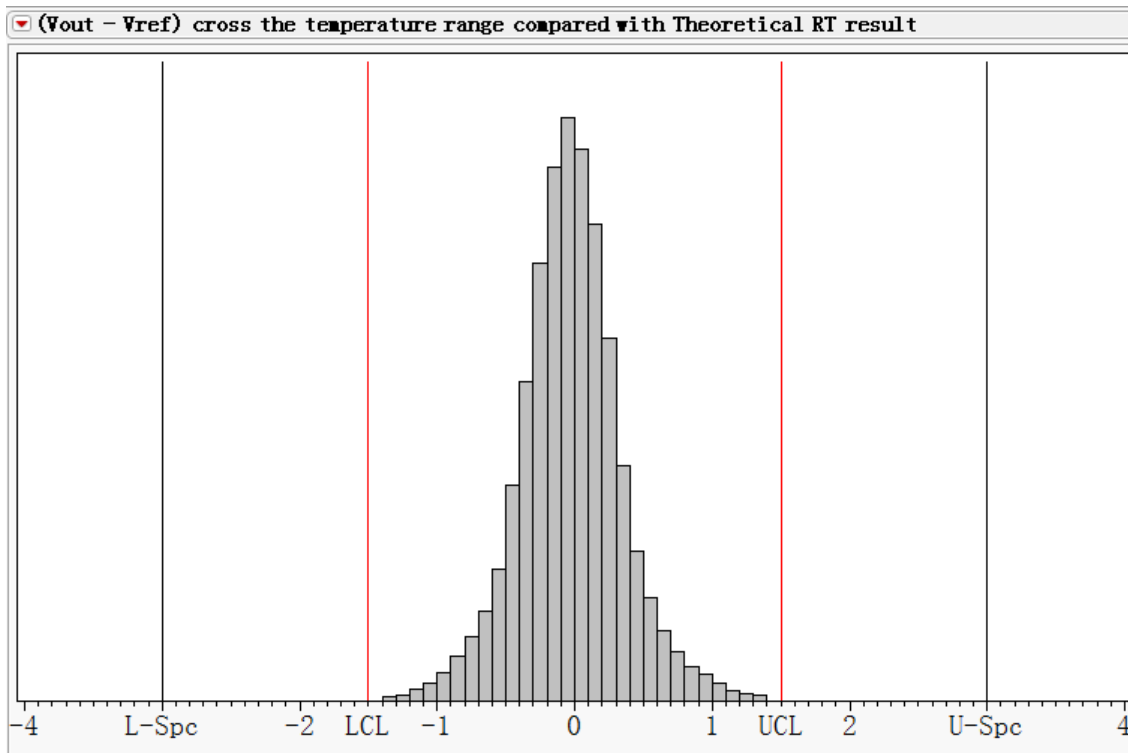

The error of STK-PL output  $(V_{out} - V_{ref})$  current sensor at  $-40^{\circ}\text{C} \sim 105^{\circ}\text{C}$  compared with the standard output  $(V = G_{th} * I_n)$ ,  $((V_{out} - V_{ref}) @ I_n @ T_x - G_{th} * I_n) / V_{FS}$ , Where,  $I_n$  represents present primary current,  $T_x$  the present temperature,  $G_{th}$  the theoretical gain,  $V_{FS}$  the rated output voltage.

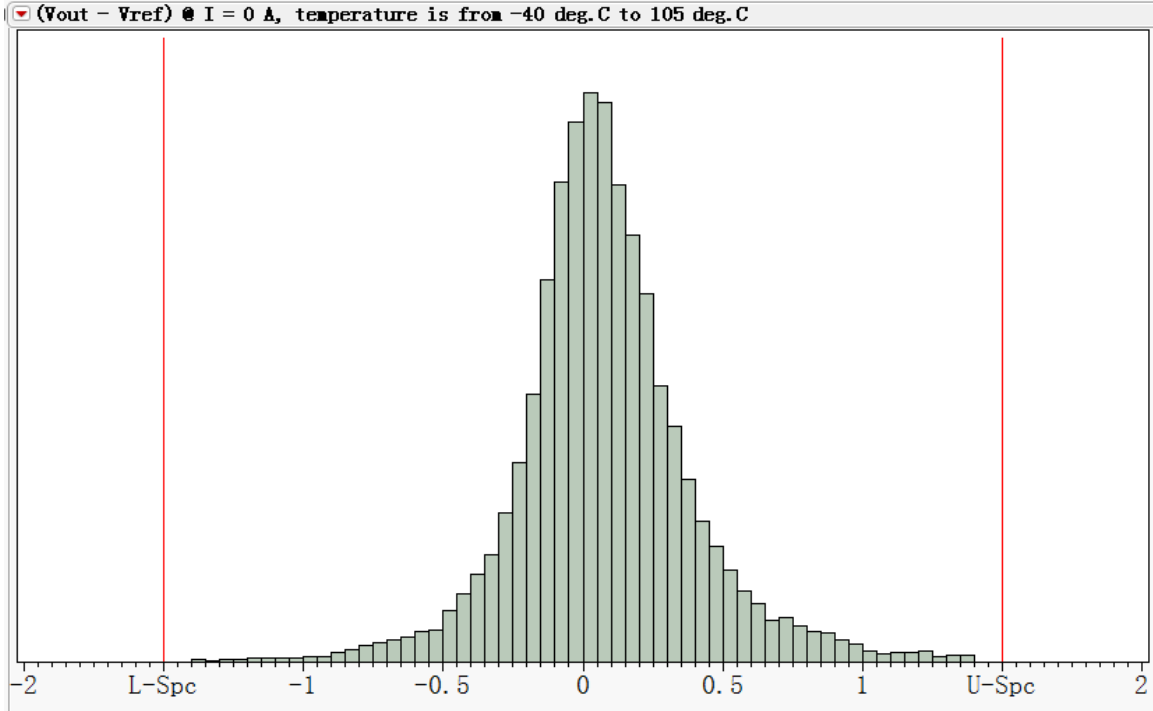

Temperature drift of Voe,  $V_{oe\_TRange} = (V_{oe} @ T_x - V_{oe} @ 25^{\circ}C) / V_{FS}$ .  $T_x$  represents present temperature,  $V_{FS}$  the rated output voltage.

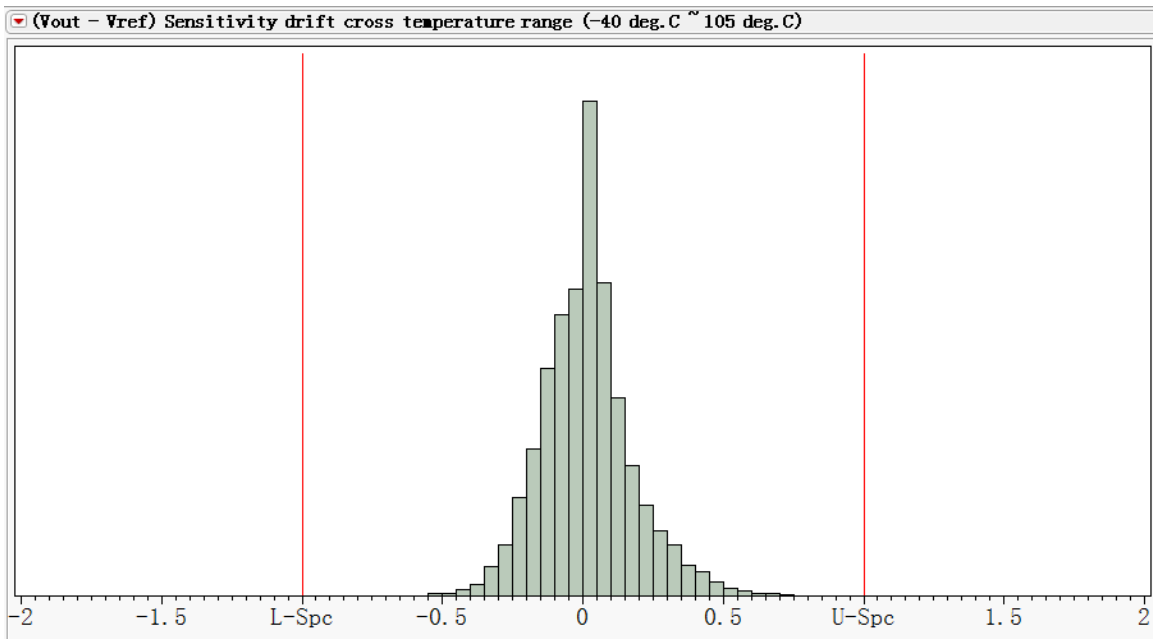

Error of gain,  $Err\_G = (((V_{out} - V_{ref}) @ I_{pn} - (V_{out} - V_{ref}) @ (-I_{pn})) / 2) - V_{FS} / V_{FS}$ . Where  $I_{pn}$  represents the rated current,  $-I_{pn}$  the reversed rated current.

## 8. Frequency response and bandwidth

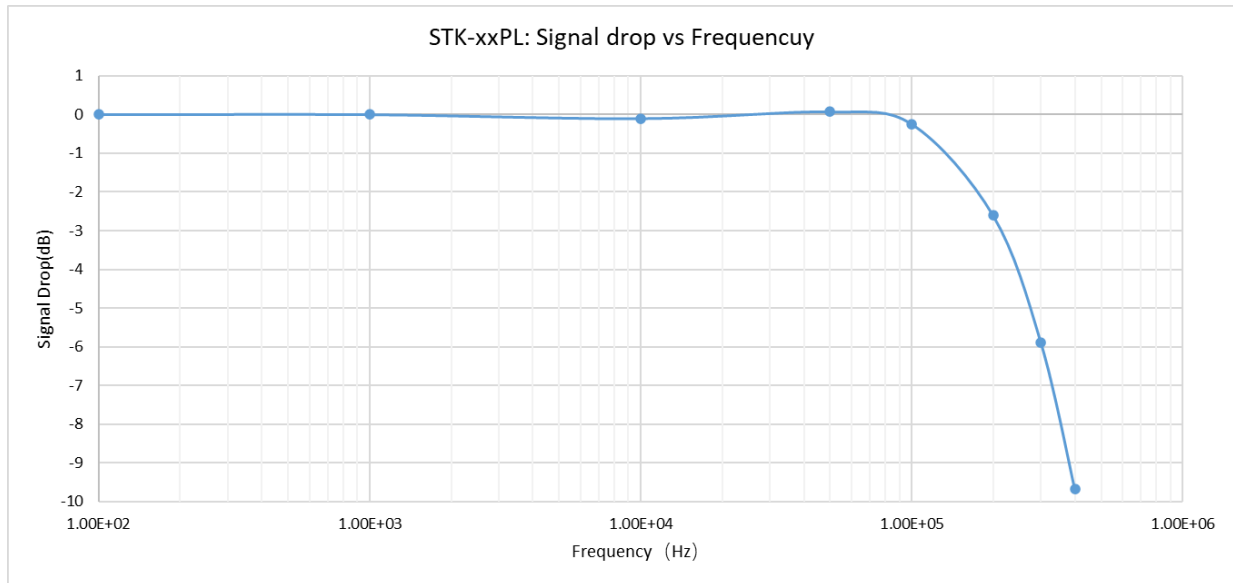

The frequency bandwidth of STK-xxPL series current sensor. The bandwidth of current sensor is DC ~ 200 kHz (-3dB).

## 9. Step response time

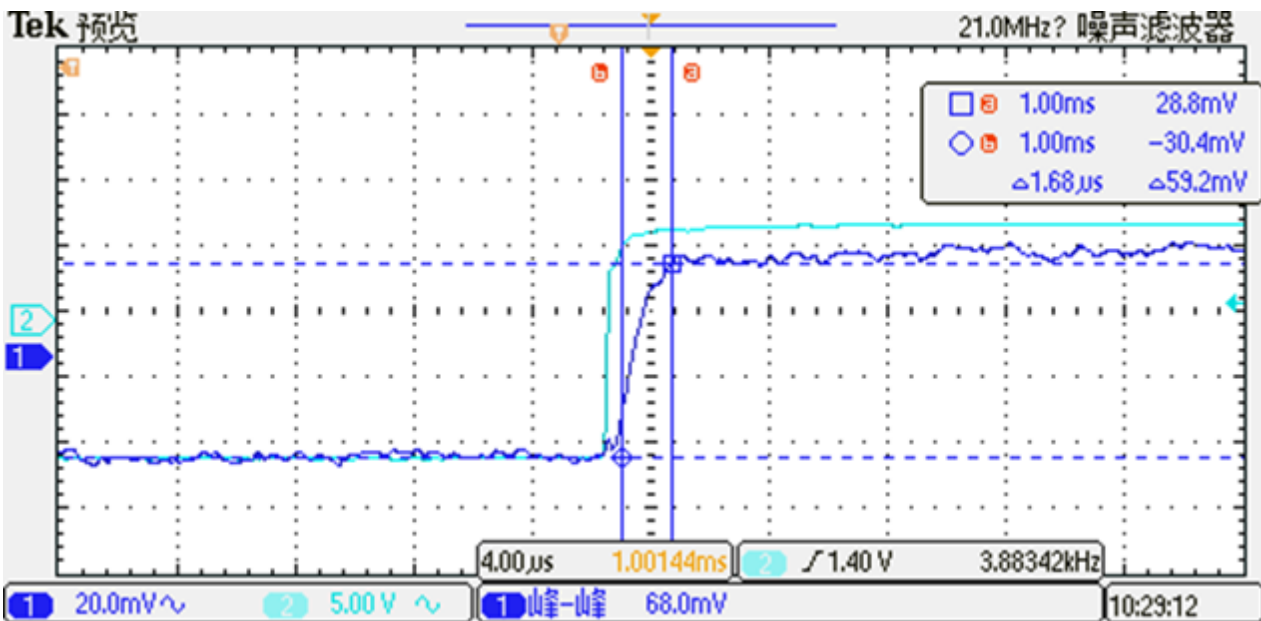

The typical frequency response of STK-xxPL current sensor. The response time from 90% of the primary current (light blue) to 90% of the secondary output (dark blue) is less than 2.5 μs

## 10. Frequency delay performance

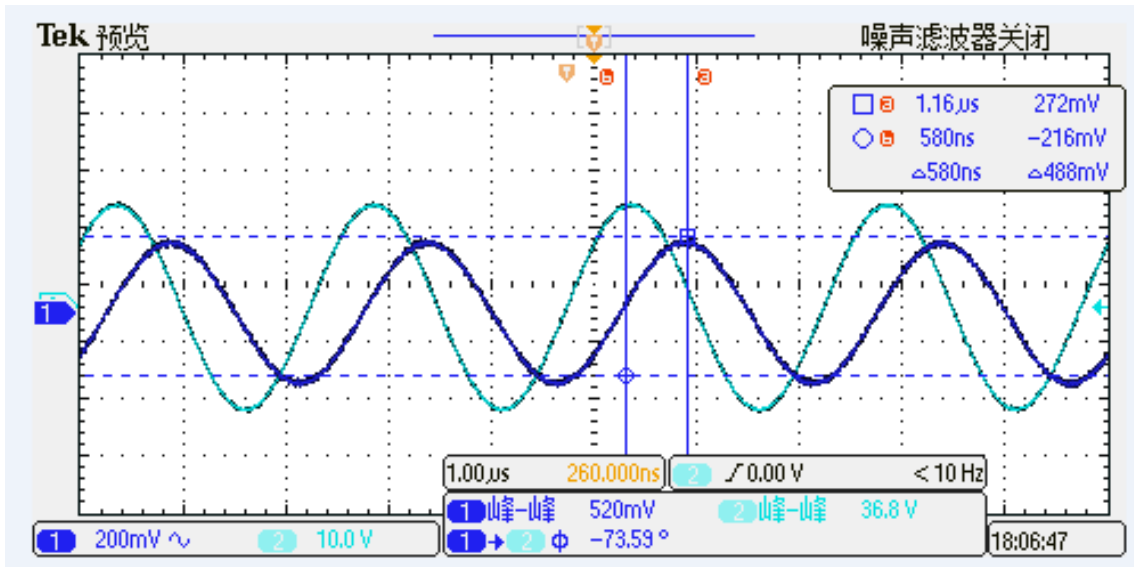

When testing 200 kHz sine wave, the typical result of STK-xxPL current sensor's output. The response time from the primary current (light blue) to the secondary output (dark blue) is less than 1 μs.

## 11. Recommended PCB layout

Installation of view: overlooking (unit: mm)

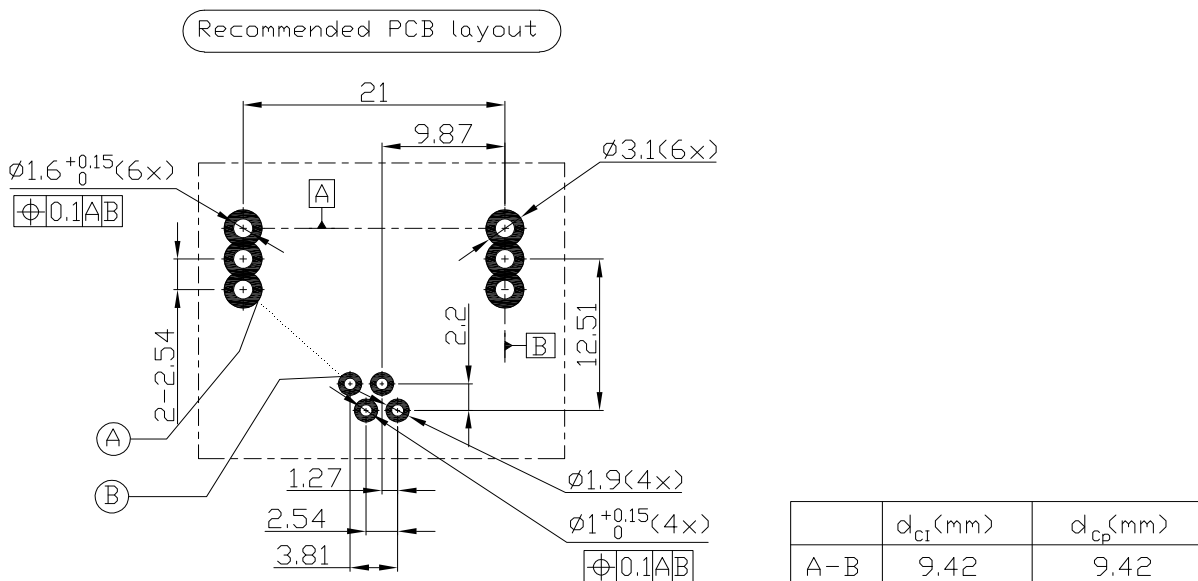

1. Installing angle: Overlook (observe from the side of installing transducer)
2. Recommended bore diameter of primary current line, (diameter of primary current  $\times 1.2$ ) mm
3. Recommended bore diameter of secondary current line, (diameter of secondary current  $\times 1.2$ ) mm
4. The maximum thickness of PCB is 2.5 mm
5. The curve of wave soldering:  $260^{\circ}\text{C} \times 10 \text{ s}$



### Security:

This current sensor must be used in limited-energy secondary circuit according to IEC 61010-1.

- This current sensor must be used in electric/electronic equipment with respect to appliance standards and safety requirement in accordance with the manufacture's operating instructions;
- When operating the current sensor, certain parts of the module can carry hazardous voltage;
- Failure to wiring as shown in the diagram will damage the current sensor;
- Ignoring this warning can lead to serious consequences.
- A protective housing or a additional shield could be used.
- Main supply must be able to disconnected.

## 12. Dimension & Pin definitions

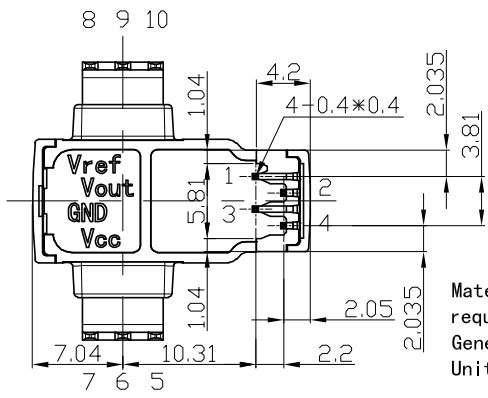
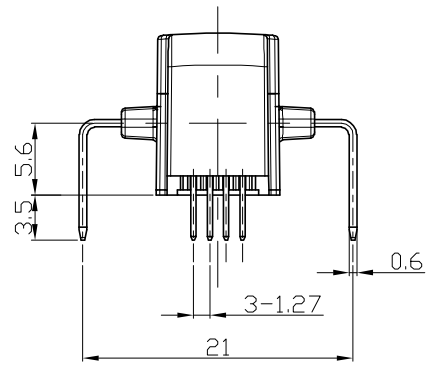
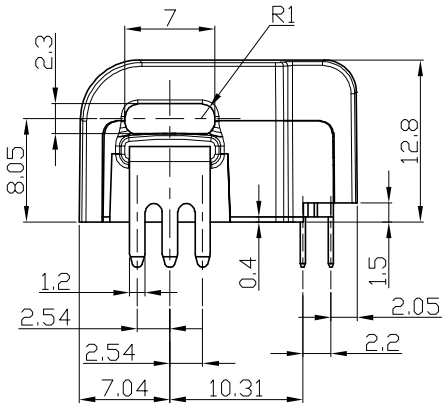
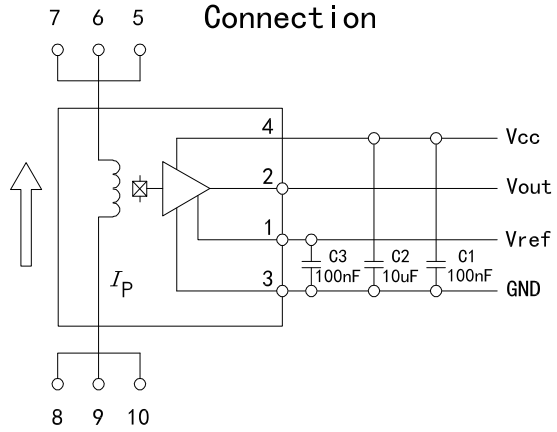
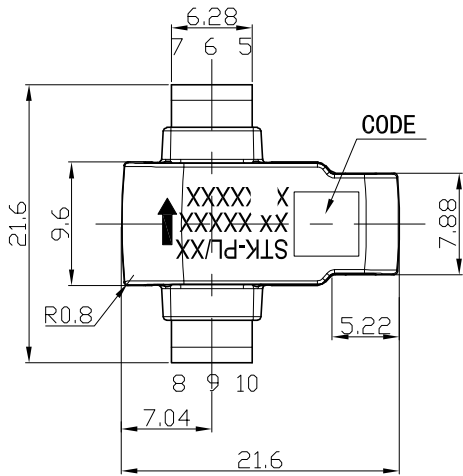

- Terminal Pin Identification**
- 1 : Vref
  - 2 : Vout
  - 3 : GND
  - 4 : Vcc
  - 5, 6, 7 : Primary input Current (-)
  - 8, 9, 10 : Primary input Current (+)

Material : Fit UL94V-0 & RoHS requirements ;  
General tolerance :  $\pm 0.5$   
Unit : mm

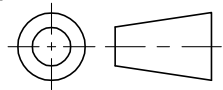

### 13. Appendix: typical application circuit

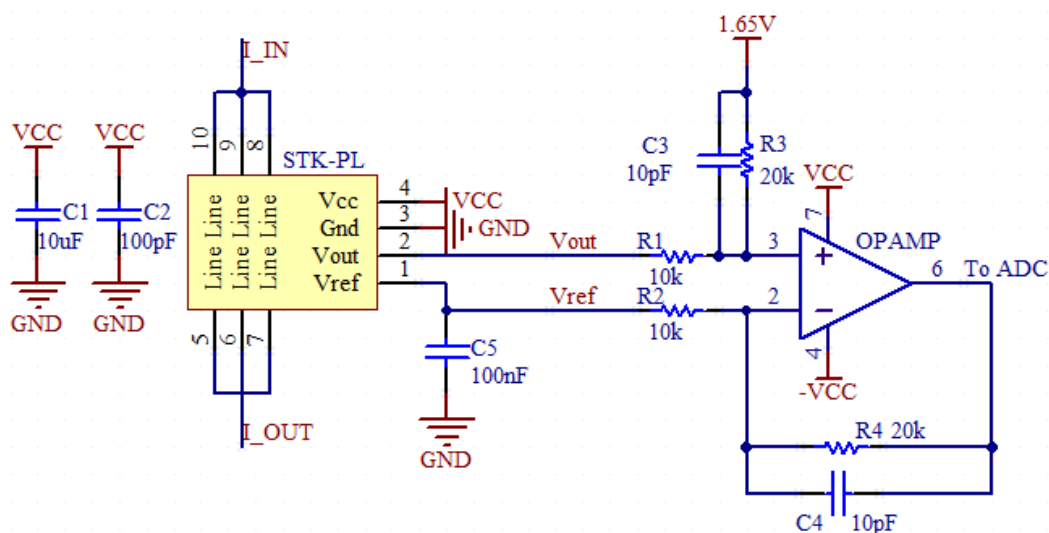
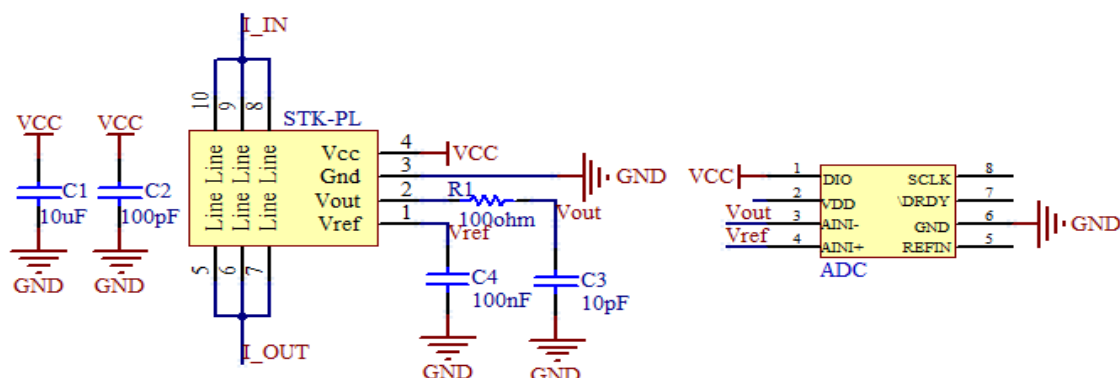

R3 (kohm)	C3 (pF)	Theoretical -3dB $f = 1/(2\pi RC)$ (kHz)	Measured -3dB (kHz)
20	40	198	~ 200
20	81	98	~ 100
20	810	10	~ 10

The frequency characteristics of STK-xxPL series current sensor are not affected by the R-C setting (according to recommended R-C setting), therefore the active filter circuit or R-C circuit can be applied to modulate the sensor's frequency characteristics.

The signal input to ADC is  $1.65 + R4/R2 * (Vout - Vref)$  with the conditions:  $R1 = R2, R3 = R4, C3 = C4$ .